

KIWO XTS™

Introducing the latest generation of CTS systems brought to you by KIWO®. The KIWO XTS™ offers the highest resolution and speed combination of any other wax-based inkjet system available today.

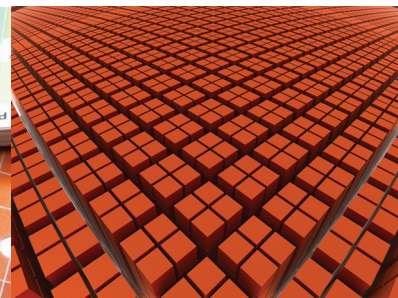

Key Features

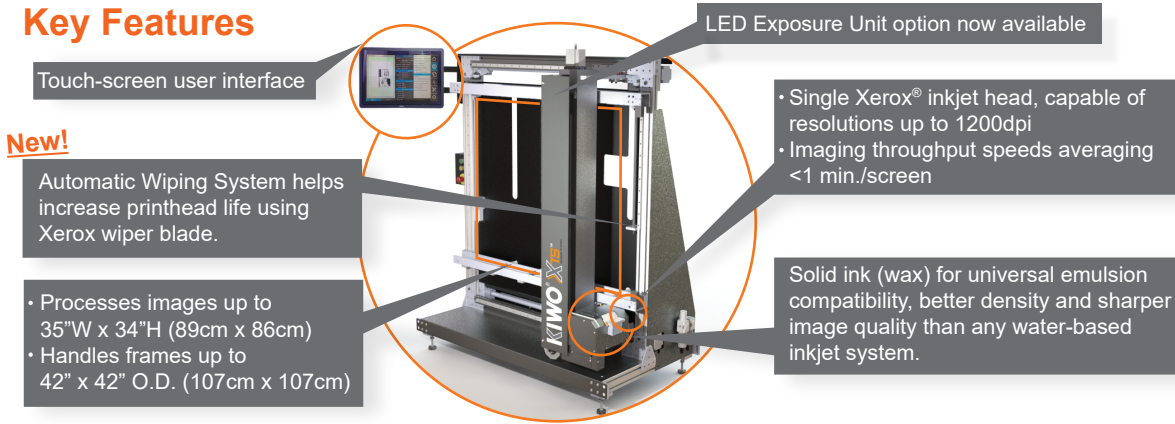

New!

Automatic Wiping System helps increase printhead life using Xerox wiper blade.

- Processes images up to 35"W x 34"H (89cm x 86cm)
- Handles frames up to 42" x 42" O.D. (107cm x 107cm)

LED Exposure Unit option now available

- Single Xerox® inkjet head, capable of resolutions up to 1200dpi
- Imaging throughput speeds averaging <1 min./screen

Solid ink (wax) for universal emulsion compatibility, better density and sharper image quality than any water-based inkjet system.

Advantages of solid ink (wax) over water-based systems

- Solid ink has higher optical density than water-based inkjet systems, offering the opacity required to **properly** cure thick or very light sensitive (fast) photo-emulsions
- Solid ink does not bleed or wick into the unexposed emulsion like water-based ink, offering superior edge definition, halftone dot control and integrity
- Solid ink is not susceptible to running, absorbing, beading (due to surface tension), or other variables that affect emulsion compatibility
- Solid ink does not stain mesh

Fast Return On Your Investment

The advantages of the digital workflow with the KIWO XTS™ lead to a rapid ROI by:

- Eliminating film costs
- Reducing reject rates in screenmaking by virtually eliminating pinholes
- Reducing exposure times by approximately 40% (no film or glass)
- Repeatable & accurate registration for faster job setup and turn-around
- Reduction of the work steps from 13 (traditional film process) to only 4
- No film storage
- Faster set-up times at the printing press
- Higher productivity and shorter delivery times
- **Barcode scanner for file import now available!**
- **Custom multi-frame JIGs now available!**

Equipment Package

- KIWO XTS™ Computer-to-Screen machine with LINUX-based industrial machine controller, Touch-screen monitor & mount
- Mac-based Harlequin RIP-station including FTIFF license (Windows RIP Available)
- Three-point registration standard
- Safety floor mat
- Automatic Printhead Wiping System standard

KIWO XTS™ Specifications

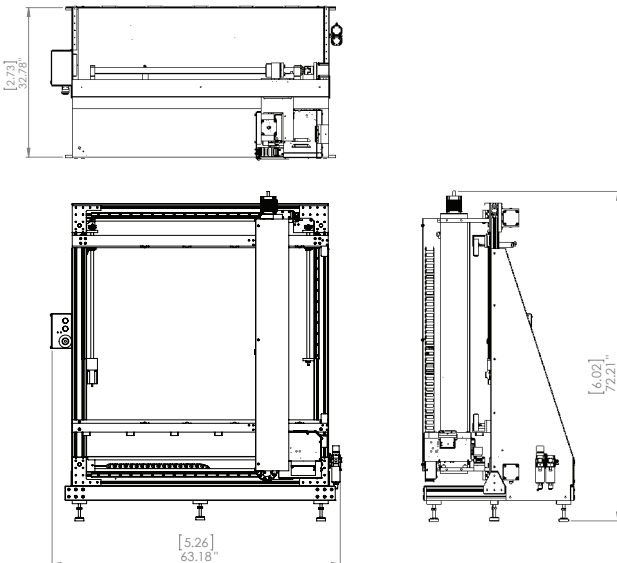

Maximum Screen Frame Sizes:	42"W x 42"H / 107 x 107 cm (Side Loading) 42"W x 40"H / 107 x 102 cm (Front Loading)
Minimum Screen Frame Sizes:	20"W x 20"H / 51 x 51 cm
Maximum Frame Profile Thickness:	2" / 5 cm Standard roller frames or box profile stretch & glue frames. <small>***Other frame profiles need to be verified with KIWO for suitability.</small>
Minimum Image Margins:	Top & Bottom: 4.5" / 11.5 cm Left & Right: 3.5" / 9 cm <small>*Minimum margins between image file and outside edge of frame. **Values based on 2" frame profile/ verify margins with KIWO for other frame dimensions.</small>
Maximum Image Size:	35"W x 34"H / 89 x 86 cm (On max. frame size with 2" profile)
Maximum Frame Profile Thickness:	2" / 5 cm Standard roller frames or box profile stretch & glue frames.
Controller Type:	LINUX-based industrial PC controller with touch-screen user interface
Data Format / RIP:	1-bit TIFF / Mac-based Harlequin RIP
Head Technology: Resolution:	Xerox® industrial solid ink print head (880 nozzle) Auto-detect: 900 / 1200 / 1500 dpi.
Compatible Stencil Material:	Compatible with all typical stencil making materials.
Network Interface:	Ethernet 100/1000 Mbps.
Environmental Conditions: Operating temperature: Humidity:	Dust free office-type environment. 60-80°F 45-75% Non-condensing
Voltage Requirements: Power Min - Max:	120VAC / 60Hz. - (10 Amp dedicated circuit) 250 - 650 Watts
Weight:	700 lbs / 318 kg.

KIWO provides innovative solutions for all of your screen making needs. We would love to discuss your application needs, and how we can help to optimize your process.

Please contact us today!

KIWO
ONLINE



KIWO Inc. - Kissel + Wolf GmbH
1929 Marvin Circle • Seabrook, TX 77586 • USA
Phone +1 281 474 9777

www.kiwo.com